

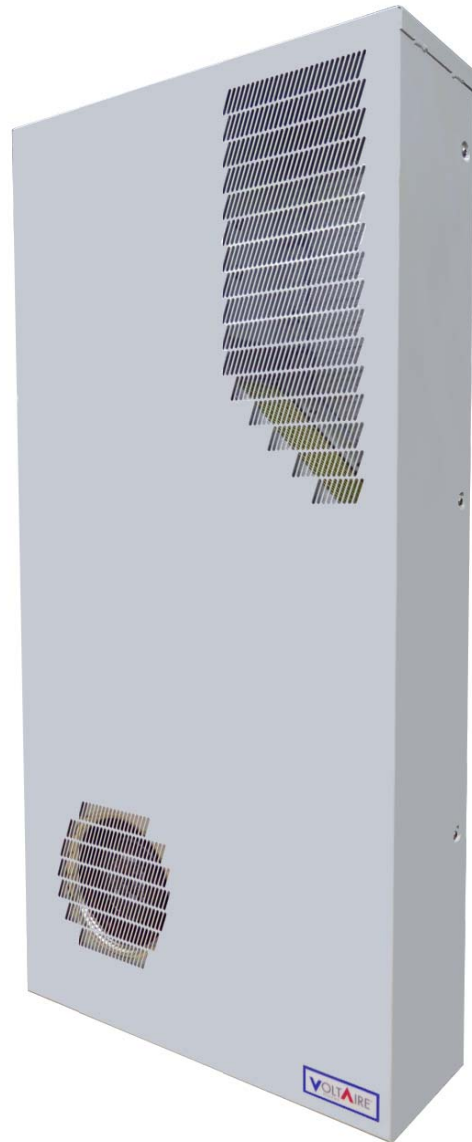

# Installation, Operation and Maintenance Manual for HETX and HEIX Series Heat Exchangers

**Air-to-Air Cross Flow  
Heat Exchangers  
with Capacity of  
18W/F through 55W/F**

**48VDC, 115VAC &  
230VAC Models**



## Revision History

| Revision* | Description              | Revised By | Date       |
|-----------|--------------------------|------------|------------|
| A         | Changed 15 W/F to 18 W/F | RAG        | 10/26/2016 |
| B         | UL Safety and Type 3R    | GAD        | 01/11/2017 |
|           |                          |            |            |
|           |                          |            |            |
|           |                          |            |            |
|           |                          |            |            |

\*More recent revisions may be available at [www.voltairesys.com](http://www.voltairesys.com) or the QR Code below. Please check for more recent updates.



## Table of Contents

|   |         |
|---|---------|
| 1. Important Information to Review Prior to Installation, Operation and Maintenance ..... | Page 3  |
| 2. Parts Shipped Loose and Tools Required.....  | Page 3  |
| 3. Product Description .....  | Page 4  |
| 4. General Product Data .....   | Page 5  |
| 5. Installation Instructions .....  | Page 8  |
| 6. 48VDC Wiring, Startup and Controls Operation.....                                      | Page 9  |
| 7. 115/230VAC Wiring, Startup, and Controls Operation.....                                | Page 10 |
| 8. Cutout Drawings .....  | Page 12 |
| 9. Electrical Wiring Diagrams.....  | Page 14 |
| 10. 48VDC Control Board Trouble Shooting .....  | Page 17 |
| 11. Recommended Maintenance.....  | Page 17 |
| 12. Spare Parts.....  | Page 19 |
| 13. Warranty .....  | Page 20 |

## 1. IMPORTANT INFORMATION TO REVIEW PRIOR TO INSTALLATION, OPERATION AND MAINTENANCE

- **Read the ENTIRE MANUAL prior to installing and maintaining** the heat exchanger. Do not install or perform maintenance on the heat exchanger if you do not understand all of the instructions. Contact VoltAire at (407)378-7482 with any technical questions or concerns.
- **Warning: Improper installation and operation may cause property damage, personal injury or loss of life.** The heat exchanger shall only be installed and maintained by a qualified professional in strict accordance with the requirements within this manual and in accordance with all local, state and federal codes.
- In the event of a conflict, code requirements shall take precedence over the instructions provided within this manual. The installer shall be aware of all code requirements and shall comply fully.
- Use care when transporting and lifting the heat exchanger.
- Remove power from the unit during maintenance and installation, as line voltage may be dangerous, hazardous and lethal.
- **Warning: Wear proper personal protection equipment, including but not limited to safety glasses, goggles and gloves. Edges may be sharp.**
- A field provided time delay fuse or breaker must be provided with the power supply circuit serving the heat exchanger. The installer shall size this fuse or breaker in accordance with all applicable codes. Verify wire terminals and voltage prior to plugging into the heat exchanger, otherwise you may damage the heat exchanger's electrical components.
- For 48VDC power supply, verify polarity and apply correctly as improper operating voltage may result in unit damage.
- These instructions should be retained by the owner and/or with the unit.

## 2. Parts Shipped Loose and Tools/Materials Provided by Installer

### Materials Shipped Loose with the Heat Exchanger

- a) Gasket kit
- b) Two (2) M6X25 Threaded Stud with two (2) M6 Nuts and two (2) M6 Lock Washers
- c) M6x25 Mounting Bolts (Quantity will vary based upon Model)
- d) 48" Long Wire Lead with Male Molex Plug (48 VDC Models Only)

### Required Tools and Materials provided by Installer

- a) Fuse or Breaker
- b) Exterior rated silicone sealant

- c) M4 Torx tamper resistant screw driver
- d) M6 HEX head screw driver
- e) M6 Nut Driver/wrench
- f) Torque wrench

### 3. Product Description

Voltaire Systems HETX and HEIX Series Cross Flow Heat Exchangers are designed for high efficiency and high performance heat transfer in a closed airflow loop to prevent introduction of exterior air into the equipment/cabinet. The heat exchangers are an industrial heat management system especially designed for heat management of electronic enclosures or equipment, including those requiring battery backup. This product is a passive thermal management system without a refrigeration system and is designed for applications where the interior temperature may exceed the exterior (ambient) temperature. This product will work in extreme temperature range from -20°C to 70°C.

Figure 1 shows the exterior and interior airflow intake and exhaust locations. Exterior air enters the heat exchanger in the bottom front left corner, and exhausts in the upper front right corner. Interior air enters the intake on the rear top left and discharges out of the rear bottom right.

The heat exchangers are UL/cUL Recognized per UL 1995/CSA 22.2 NO. 236-15 and UL tested and UL Recognized for compliance with UL Type 3R. HETX Series fans are salt fog certified by a 3rd party per GR-487-CORE 3.34.1 and ASTM B117 for 720 hours. The aluminum heat exchanger core is coated with epoxy for additional durability in corrosive atmospheres.

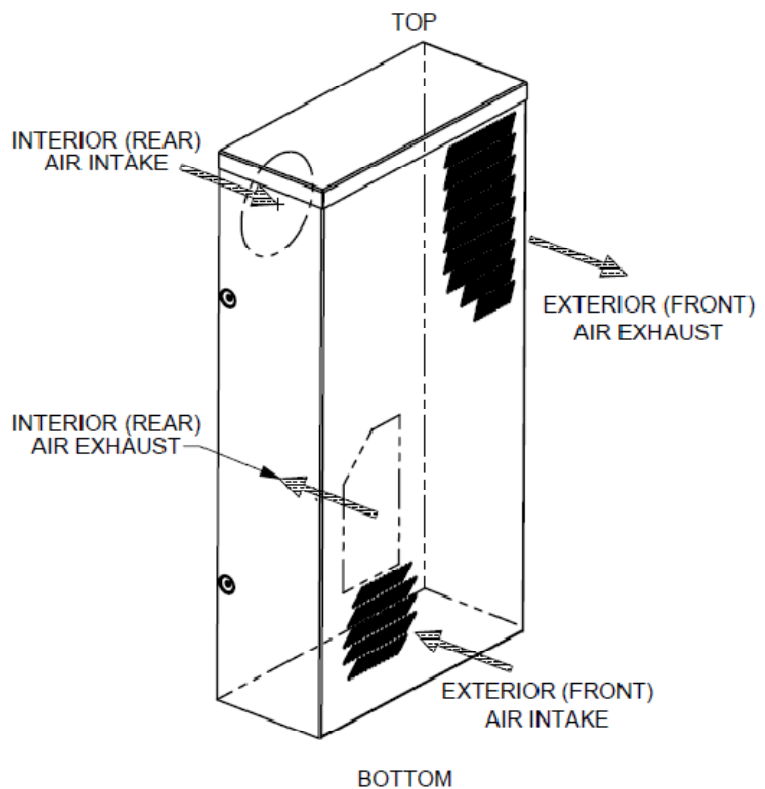

**Figure 1 - Airflow**

For the 48VDC models, an integral 48VDC control board is used to control fan speed to optimize energy performance while minimizing noise. The board is programmed to operate the interior and exterior fan based upon the interior temperature within the cabinet, equipment or building. The interior fan will operate at 25% capacity continuously when the cabinet is above 0°C and below 30°C. At 30°C, the exterior fan will energize and both the exterior and interior fans will modulate from 25% to 100% between 30°C and 44°C. Reference Figure 10 for fan speed design based upon interior temperature.

The 48VDC board includes a general alarm for loss of fan or high temperature, with a continuous 12VDC output provided when no alarm is present. The 48VDC board is accessible from the interior exhaust opening of the internal airflow, or if inaccessible from the interior, accessible by removing the cover and front panel of the unit. The 48VDC board includes a test button to verify operation, as described in Section 6.

For 115/230VAC models, an optional snap temperature disc is available to operate the fans above a predetermined temperature.

For the Telecom Series (HETX), or as an option on the Industrial Series (HEIX), VoltAire's Patent Pending Rain Guard Deflector provides an indirect airflow path that significantly reduces water intake into the outside airflow chamber. Although both the HEIX and HETX are UL Certified Type 3R without the Rain Guard Deflector design, the addition of the Deflector provides additional protection against water intrusion to improve long term reliability.

The heat exchanger cabinet and brackets are fabricated out of acrylume for improved durability, a powder coated cover, and security screws attaches the cover to the heat exchanger. The unit is easily mounted to a cabinet or equipment with the enclosed field installed gasket and M6 mounting kit. All operable parts are accessible from the exterior of the cabinet allowing for maintenance without removal of the heat exchanger from the cabinet, equipment or building.

#### 4. General Product Data

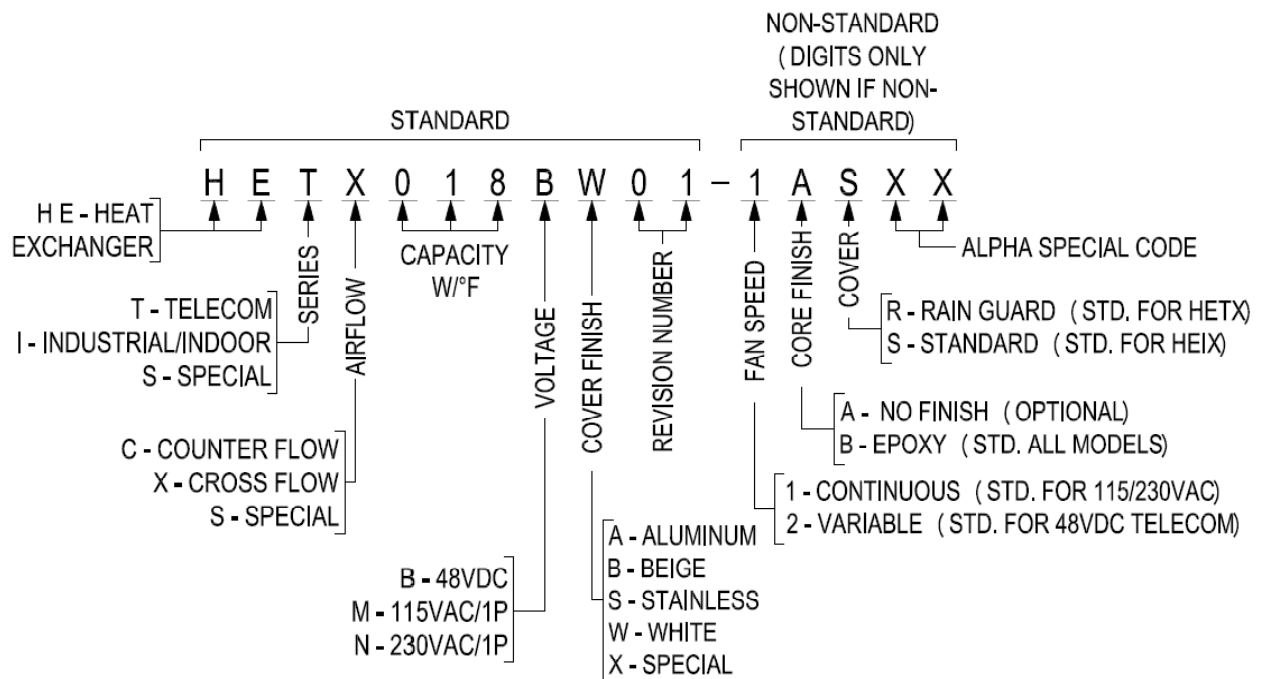

**Figure 2 - Model Nomenclature**

**Figure 3 - Unit Dimensions**

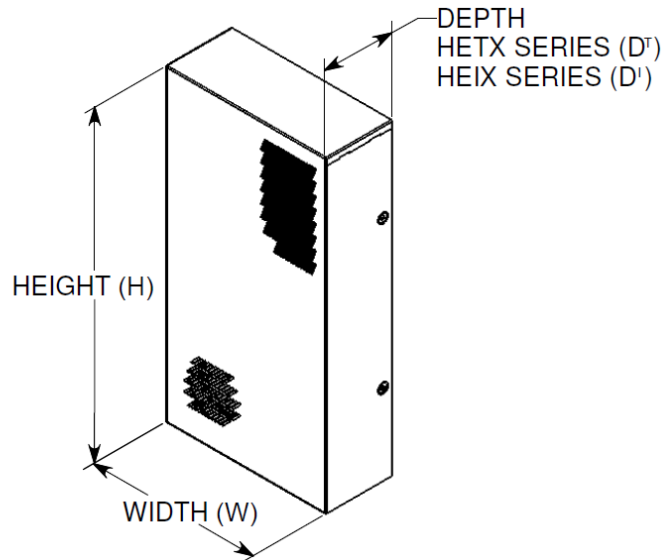

| Model <sup>1</sup> | Nom. Cap. <sup>2</sup><br>(W/°F) | Voltage<br>(Single Phase) | Full Load Amps <sup>3</sup> | Wt.<br>HETX/<br>HEIX<br>lbs. | W<br>in.<br>(mm) | H<br>in.<br>(mm) | D <sup>T</sup><br>in.<br>(mm) | D <sup>I</sup><br>in.<br>(mm) |
|--------------------|----------------------------------|---------------------------|-----------------------------|------------------------------|------------------|------------------|-------------------------------|-------------------------------|
| HE_X015B           | 18                               | 48 VDC                    | 1.3                         | 22/<br>19                    | 12.0<br>(305)    | 23.0<br>(584)    | 6.8<br>(172)                  | 5.3<br>(135)                  |
| HE_X015M           |                                  | 115 VAC                   | 1.0                         |                              |                  |                  |                               |                               |
| HE_X015N           |                                  | 230 VAC                   | 1.0                         |                              |                  |                  |                               |                               |
| HE_X025B           | 25                               | 48 VDC                    | 1.3                         | 23/<br>20                    | 12.0<br>(305)    | 23.0<br>(584)    | 7.5<br>(191)                  | 6.0<br>(152)                  |
| HE_X025M           |                                  | 115 VAC                   | 1.0                         |                              |                  |                  |                               |                               |
| HE_X025N           |                                  | 230 VAC                   | 1.0                         |                              |                  |                  |                               |                               |
| HE_X035B           | 35                               | 48 VDC                    | 3.1                         | 45/<br>40                    | 18.0<br>(457)    | 36.0<br>(914)    | 7.5<br>(191)                  | 6.0<br>(152)                  |
| HE_X035M           |                                  | 115 VAC                   | 1.2                         |                              |                  |                  |                               |                               |
| HE_X035N           |                                  | 230 VAC                   | 1.1                         |                              |                  |                  |                               |                               |
| HE_X045B           | 45                               | 48 VDC                    | 3.1                         | 50/<br>45                    | 18.0<br>(457)    | 36.0<br>(914)    | 8.0<br>(203)                  | 6.5<br>(165)                  |
| HE_X045M           |                                  | 115 VAC                   | 1.2                         |                              |                  |                  |                               |                               |
| HE_X045N           |                                  | 230 VAC                   | 1.1                         |                              |                  |                  |                               |                               |
| HE_X055B           | 55                               | 48 VDC                    | 4.3                         | 52/<br>47                    | 18.0<br>(457)    | 36.0<br>(914)    | 10.5<br>(267)                 | 9<br>(229)                    |
| HE_X055M           |                                  | 115 VAC                   | 1.4                         |                              |                  |                  |                               |                               |
| HE_X055N           |                                  | 230 VAC                   | 1.1                         |                              |                  |                  |                               |                               |

**Table 1 - General Product Information**

<sup>1</sup> 3rd digit of model number is Telecom (HEIX) or Industrial (HEIX)

<sup>2</sup> Capacity is nominal based upon free airflow without restrictions; Locating the heat exchanger where airflow is restricted may reduce capacity; Nominal capacity is at exterior temperature of 45°C (113°F) and interior temperature of 55°C (131°F), Δ 10°C (Δ18°F)

<sup>3</sup> Field provided fuse or breaker is required; Installer shall verify size and insure compliance with all applicable codes.

**Figure 4 -  
HEIX  
Series Heat  
Exchanger  
Configuration**

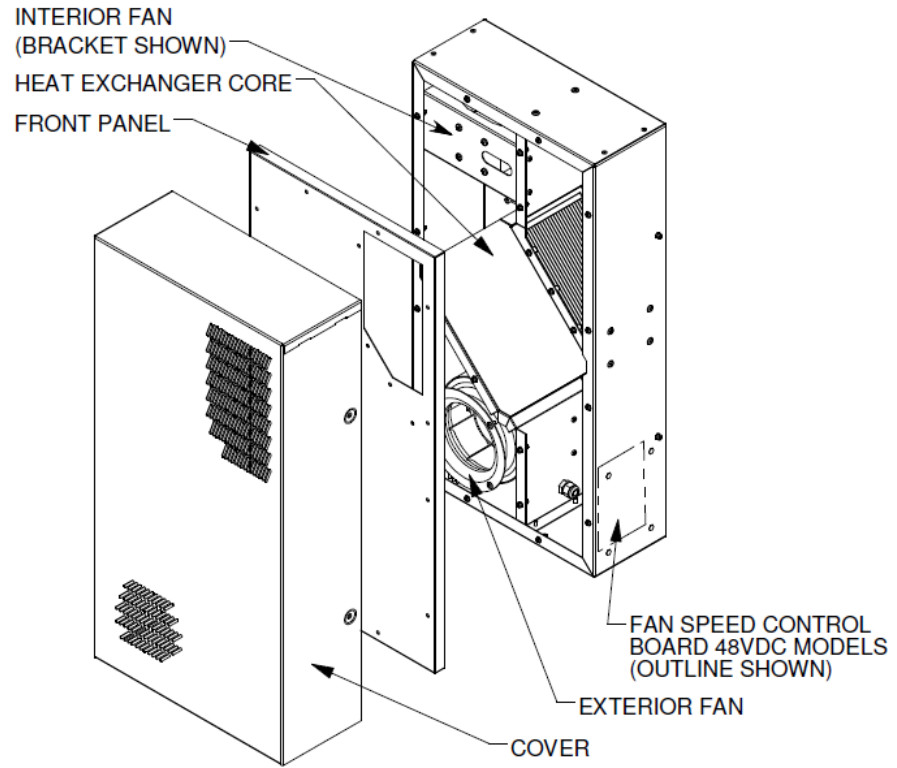

**Figure 5 - HETX  
Series Heat  
Exchanger  
Configuration  
with Patent  
Pending Rain  
Guard Deflector**

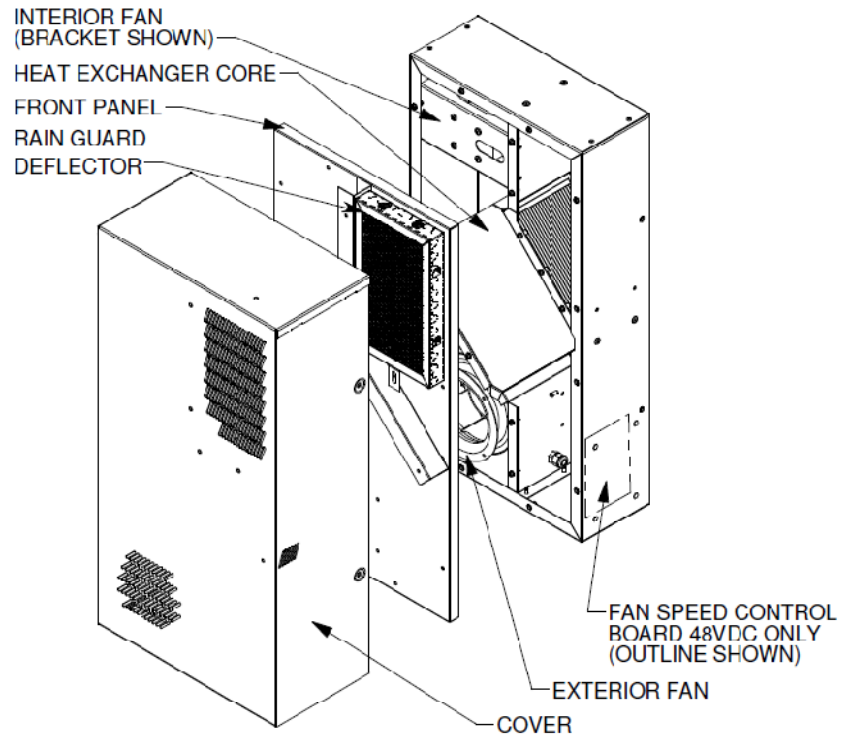

## 5. Installation Instructions

The heat exchanger can be installed on any flat vertical surface. Do not install the unit in a horizontal position and verify the unit is level. The heat exchanger should be located on a cabinet or equipment such that airflow is not restricted by obstructions of the interior or exterior intake and exhaust openings. Obstruction of airflow will reduce capacity of the heat exchanger.

Using the cutout template shown in Section 8, prepare the wall for the interior intake and exhaust openings and fastener locations. Clean the mounting surface to remove any dust, grease and/or debris, including any metal burrs resulting from metal cutting.

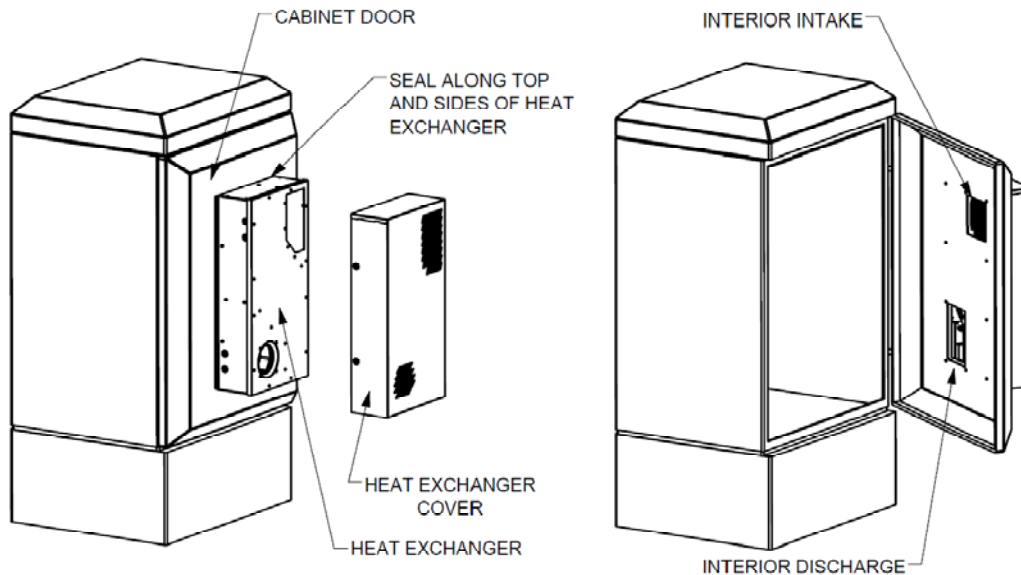

**Figure 6 - Typical Installation**

Remove the cover from the heat exchanger by removing the M4 Torx security screws on the sides of the cover. Set the cover to the side as it will not be placed back on the unit until installation is complete.

Using the gasket kit provided, place the gasket on the back of the heat exchanger immediately abutting the mounting hole locations. Figure 5 reflects the location of the gasket with the hatched area. Insure there are no gaps in the gasket and verify the entire perimeter is sealed with gasket.

Insert two (2) M6x25 threaded studs provided into the top left and right corner mounting holes on the back of the unit. These studs are provided to allow the unit to be placed on the cabinet in a temporary manner while the other fasteners are installed. Do not over-tighten these studs as they will be tightened fully when the nuts are installed. Install the M6x25 bolts and washer at each of the mounting locations. Install the M6 nuts and washers on the M6 studs. Tighten the M6 mounting bolts and nuts on the M6 studs to 50 in-lbs torque.



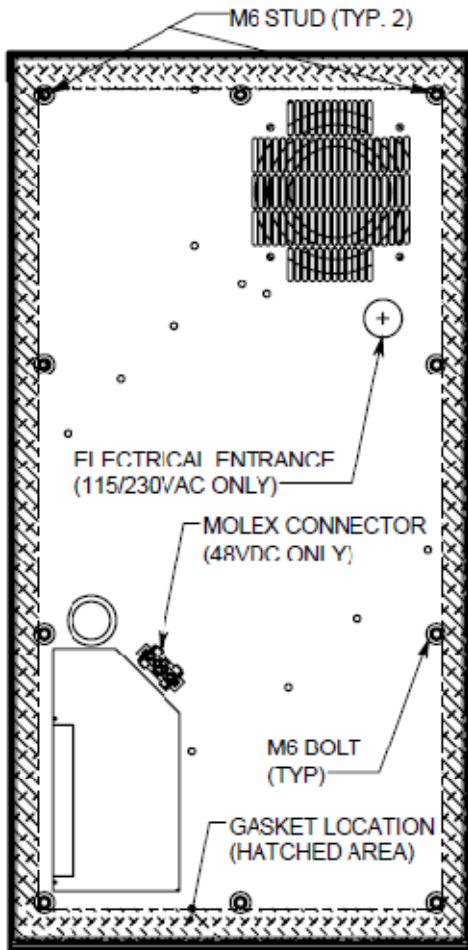

Figure 6 Heat Exchanger Installation

From the exterior, inspect the gasket to verify the gasket is tight and there are no visible leakage points. Using a field supplied sealant, seal around top and sides of the heat exchanger. Note that the heat exchanger is fully maintainable without removal from the cabinet/equipment, therefore this sealant will not be required to be removed for the purpose of routine maintenance. Therefore use a liberal amount of sealant.

Once the sealant is sufficiently dry, place the heat exchanger cover on the heat exchanger and fasten with the security screws.

Installation of the heat exchanger is complete, with the exception of applying power and starting the unit per the instructions below.

## 6. 48 VDC Model Wiring, Start Up and Controls Instructions

**STOP AND READ BEFORE PROCEEDING!** Proceed with **CAUTION** as the 48VDC must be wired with the proper polarity. Failure to connect the 48VDC power cable correctly may damage the heat exchanger control board and/or motors. Verify supply voltage is nominal 48VDC, with no more than 10% voltage variation. The connection to the heat exchanger shall be made with a male connection with the pin numbers and wire locations as shown in Figure 6. A 48" long lead with male molex connector is shipped loose for connection to the power source. A time delay fuse or breaker is required and shall be sized per applicable code. Be careful and do not short the 12VDC alarm output as the control board will be damaged. Figure 6 below reflects the molex plug and wire designations.

Ensure that the heat exchanger is fully assembled and verify that the fans are protected with the provided covers. Any loose parts/tools shall be removed and be careful to avoid body contact with the moving fans.

The 48VDC internal power cable is to be installed by the installer. The internal power/alarm wire with molex plug is shipped within the lower air flow cutout. The installer is to place the molex into the cutout on the rear of the unit, as shown in Figure 7. Insert the

molex plug into the opening snapping it into place.

Apply power to the unit. The unit may not automatically operate if temperatures are not within the range as shown on Figure (8). The control board, as shown below in Figure 7, is designed for simple operation. The board includes a test button, which will operate the fans at maximum 100% capacity for a period of 2 minutes and 30 seconds. Upon startup, press and hold the button for 2 seconds and the unit will begin test mode. The test mode will continue until the test period ends, or the test mode button is pushed again for 2 seconds.

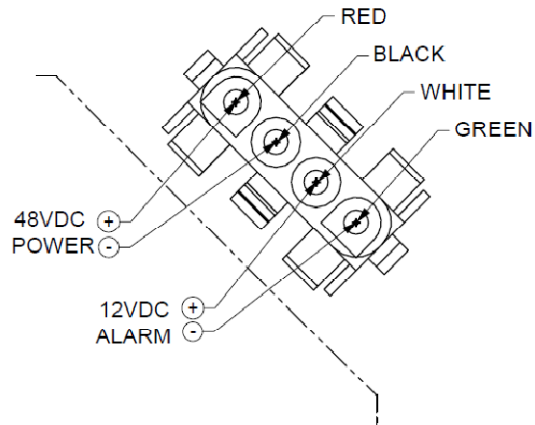

The board includes a potentiometer to adjust maximum fan speed. The default setting from the factory is maximum 100% airflow capacity. Lowering the fan speed, thus reducing heat exchanger capacity, may be necessary to reduce noise and/or to reduce energy use. To allow testing and real time adjustment of the maximum fan speed, the test button may be activated and fan speed adjusted with the potentiometer during the test sequence.

The alarm output provides a 12VDC signal while NO alarm is present. Upon a temperature alarm at 65°C, a fan failure and/or thermistor failure the 12VDC signal will be dropped to signal an alarm. This condition is fail safe such that a potential power failure will signal an alarm.

Interior and exterior fan operation is per the table below in Figure 8.

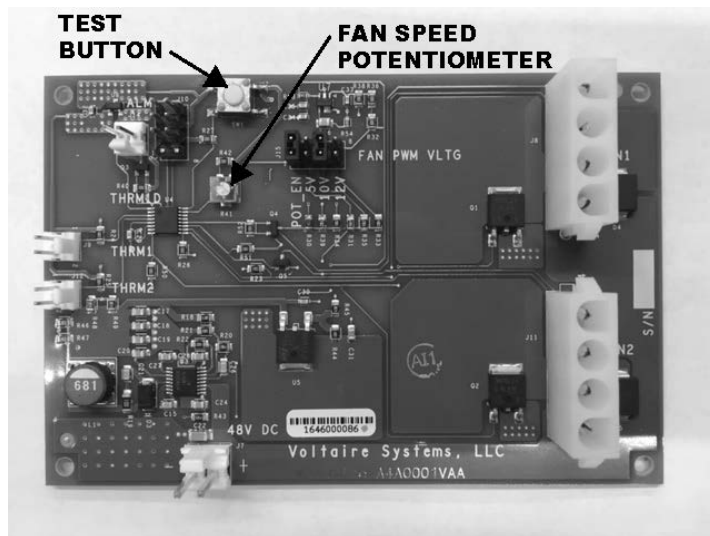

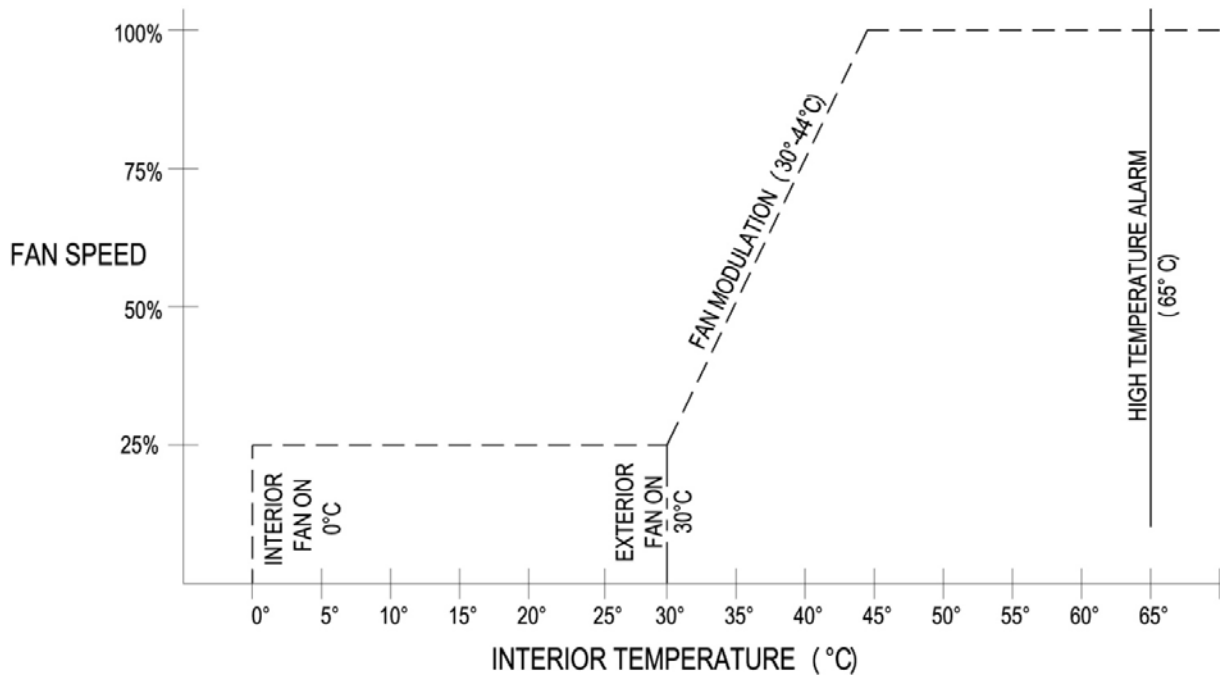

**Figure 10 - Fan Speed/Interior Temperature Graph**

## 7. 115/230 VAC Models Start Up

Disconnect power to the unit. A three conductor 48" long VAC electrical service line is provided with the unit. Install a field supplied fuse or breaker, size per all applicable codes, between the power supply and the unit. Ground the unit to the provided ground terminal.

115 and 230 VAC models do not have fan control board, but rather are powered at all times. An optional snap temperature disc may be included, which will operate the fans when the temperature is above the snap temperature disc temperature. Models with a snap disc will include a Alpha Special Code designation for the last two digits of the non-standard model number. The snap disc will be located within the interior airflow discharge plenum.

Verify that no loose parts or equipment are within the heat exchanger and all covers are installed. Apply voltage to the unit. Verify both interior and exterior fan operation.

## 8. Cabinet/Equipment Cutout Drawings

The mounting/cutout drawings below reflect the interior airflow intake and exhaust cutouts as well as the mounting hole spacing/size for the M6 mounting studs and bolts.

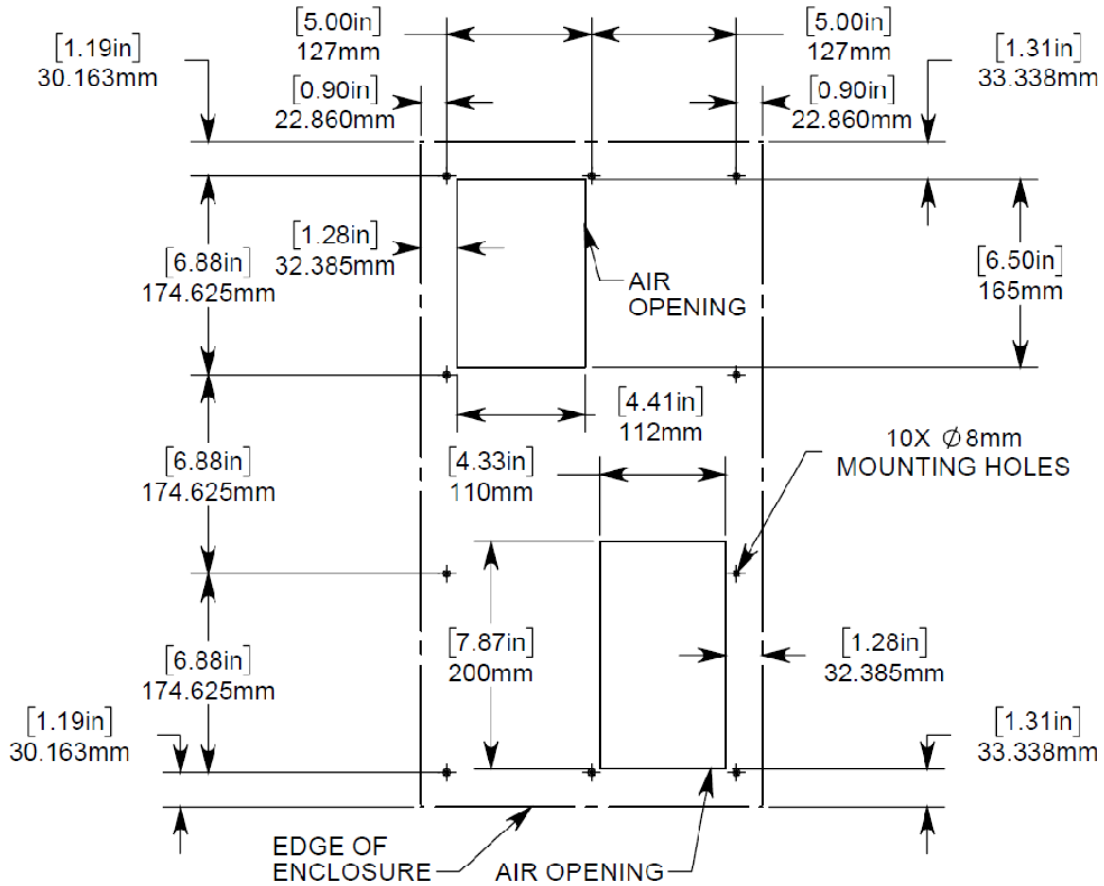

**Figure 11 - HE\*X018 and HE\*X025 Mounting Template**

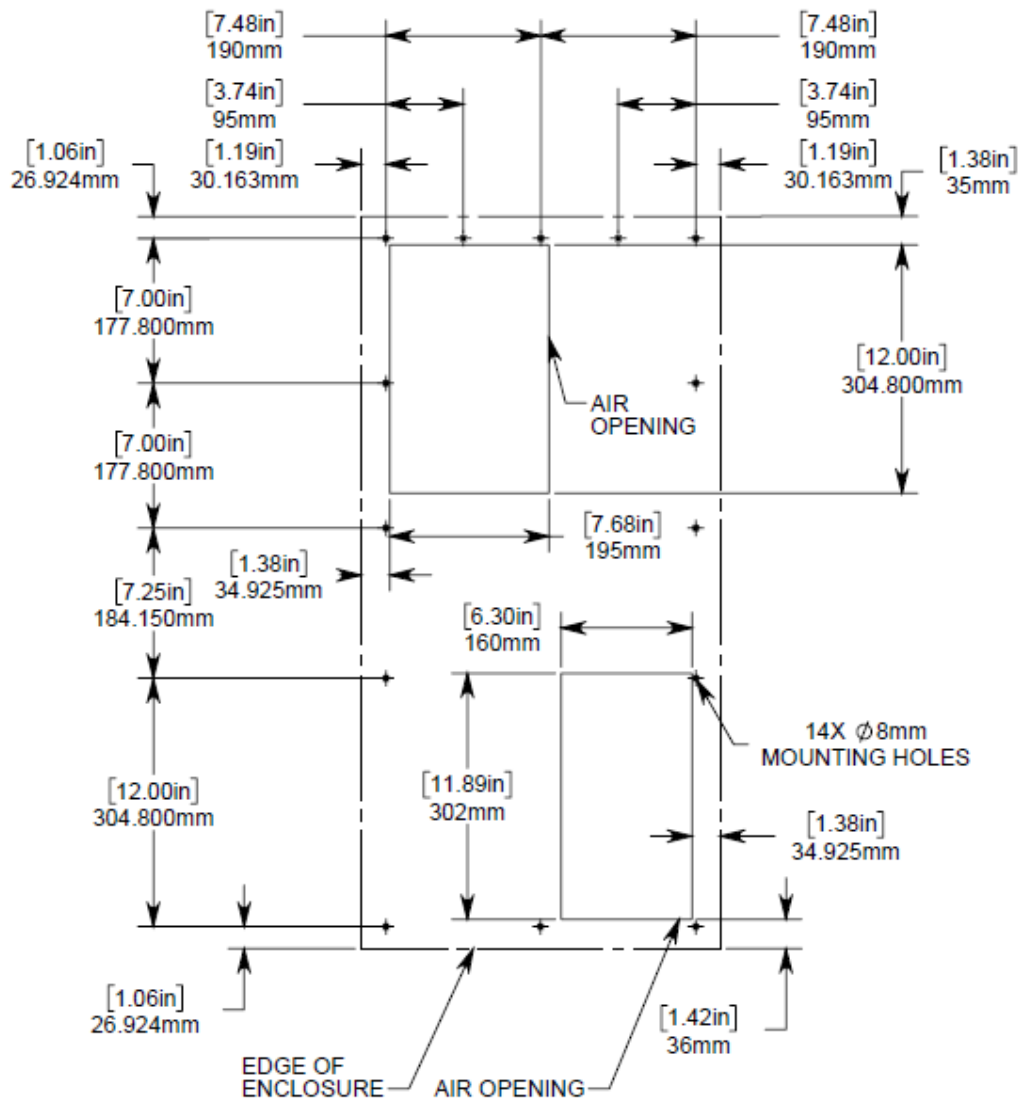
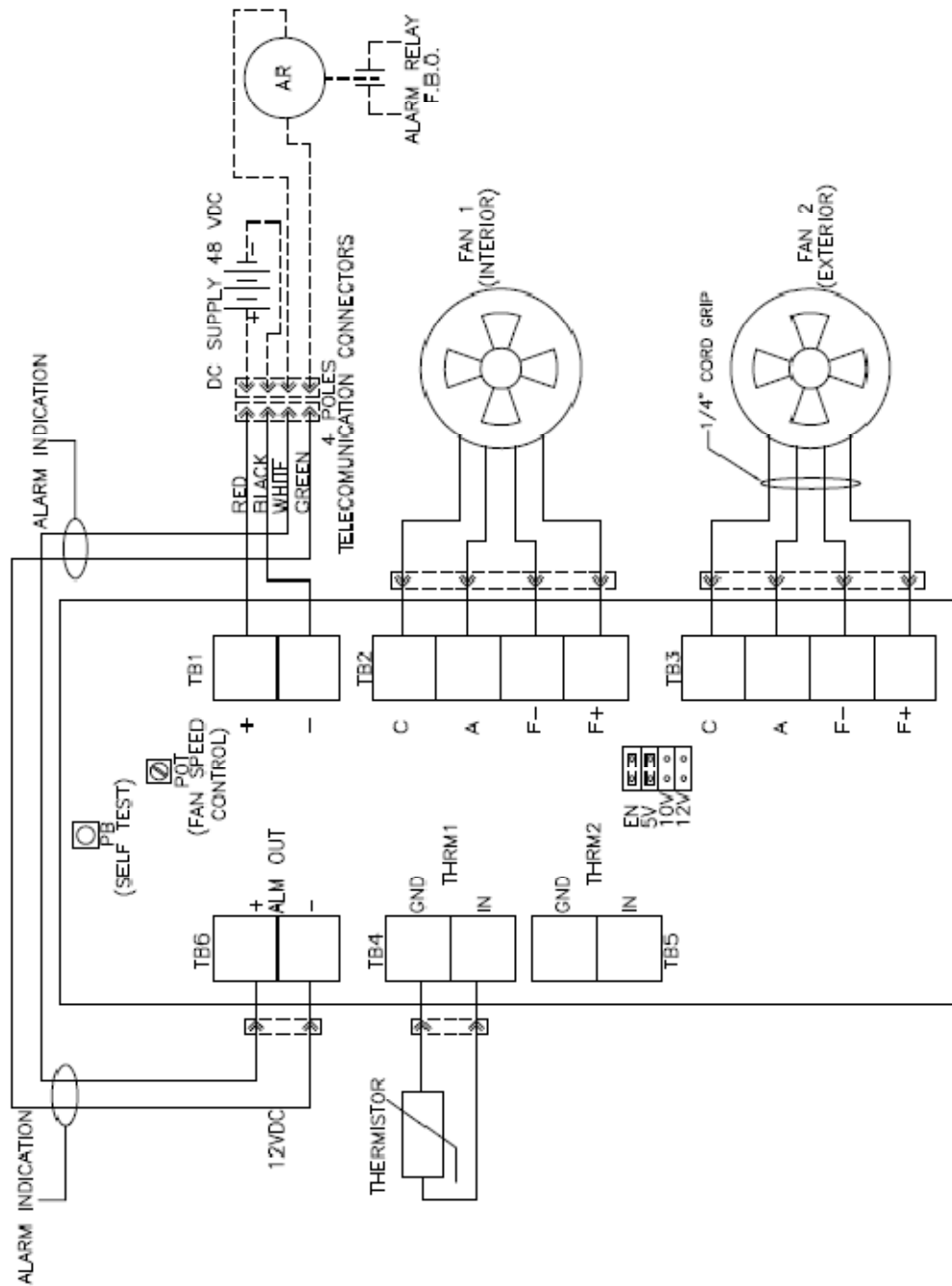
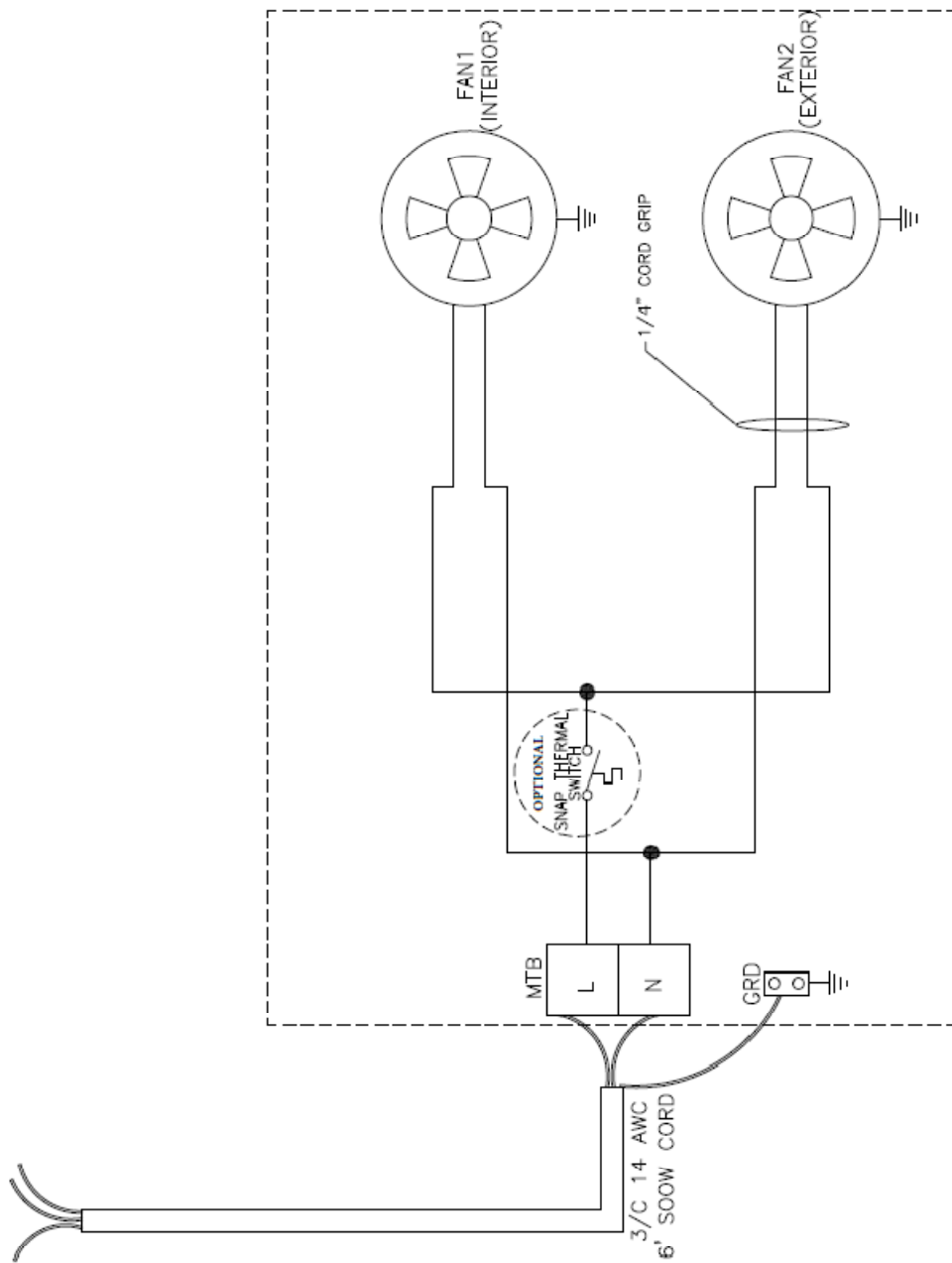

Figure 12 - HE\*X035, HE\*X045 and HE\*X055 Mounting Template

## 9. Electrical Wiring Diagrams



**Figure 13 - 48VDC Wiring Diagram for all 48VDC Models with a Speed Control Board**



**Figure 14 - HE\*X018 & HE\*X025  
115/230VAC Wiring Diagram**

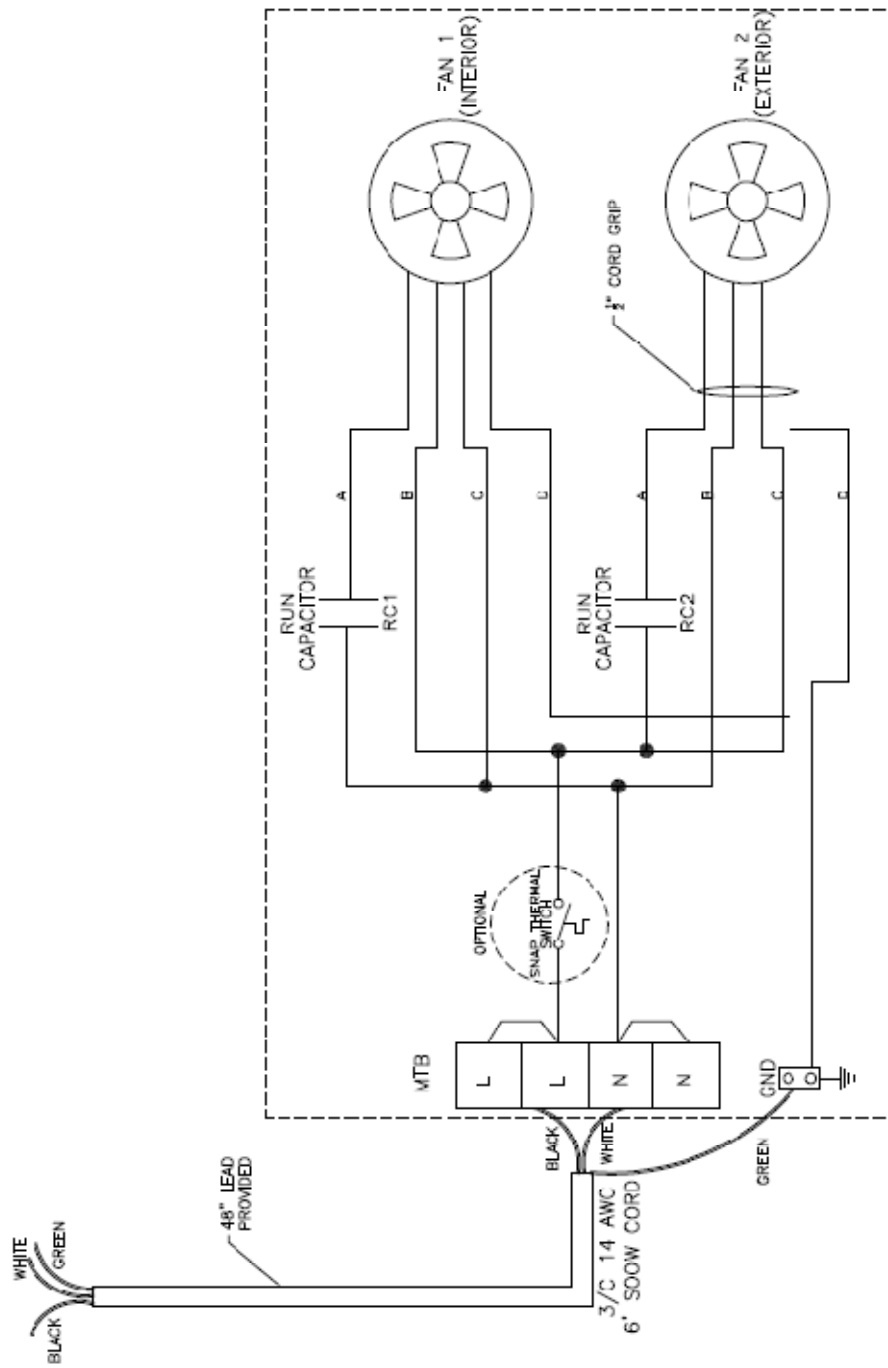

**Figure 15 - HE\*X035, HE\*X045 & HE\*X055  
115/230VAC Wiring Diagram**



## 10. 48VDC Control Board Operation and Troubleshooting

The Voltaire Systems DC control board has an alarm function that activates a 12VDC alarm under the following circumstances. The board is designed fail safe with a continuous 12VDC output when an alarm is NOT present. Upon alarm, the 12VDC output is inactive to signal an alarm. Note that these alarms are capable of being present during test mode.

- An internal temperature exceeding 65C will result in an alarm. The board will discontinue the 12VDC output but continue to command the fans to operate at 100% speed. A high temperature alarm may be the result of a bad fan motor, defective thermistor, board failure or inadequate heat exchanger size for the heat load.
- The loss of thermistor input will result in an alarm. If the thermistor is defective or disconnected, the control board discontinues the 12VDC output and the fans will operate at 100% fan speed. To access the thermistor, remove the cover and the front panel, and the thermistor is located in the upper left hand chamber of the interior airflow path (rear of unit). First check that the thermistor is properly installed and plugged into the board. If detached, plug the thermistor into the board at the THRM1 board terminal, reassemble the unit with front panel and cover, and retest. The NTC thermistor is 10,000 ohms at @ 25°C and uses the J Temperature-Resistance curve. If the thermistor is not functioning properly and has failed, remove the power from the HETX or HEIX model and replace the thermistor and retest.
- A loss of fan will result in an alarm. The board will discontinue the 12VDC output and will continue to provide a 100% fan speed command. Determine which fan is not running and operating properly by using the test button, remove power to the unit, check all wire connections to ensure you have good connections to the defective fan. If you find that there are no connection problems replace the fan. Once you have a replacement fan remove the cosmetic cover and the front cover to expose the fans, replace the defective fan, reconnect the wires, replace the front panel and cover and apply power to the unit and retest.
- A loss of power to the board will result in an alarm as the 12VDC output will not be present.

## 10. Recommended Maintenance

Although the heat exchangers are designed to require minimal maintenance, it is recommended that the units be inspected periodically for proper operation. The following items can be reviewed during other routine maintenance of the cabinet/equipment:

- Verify operation of the interior and external fans. If the model is a 48VDC model, use the control board test button to verify operation of the interior and exterior fans.

- Verify that the unit is sealed properly. The field sealing of the unit to the cabinet/equipment should be inspected to ensure proper sealing (See Section 5).
- The heat exchanger core includes two flow paths, an interior and exterior. These flow paths may be vacuumed to remove any dust and dirt. To do so, remove the supply voltage to the unit to ensure that the fans are not operating. Remove the heat exchanger cover by removing the torx security screws on the left and right side. Remove the front panel to gain access to both the interior and exterior flow paths and vacuum both sides. Replace the front panel, verify proper sealing, and replace the cover.

## 12. Spare Parts

**Table 2**

| Heat Exchanger Model Number(s)             | Part Number | Part Description                        | Picture   |           |   |
|--|-------------|---|---|-----------|---|
| HEIX***B<br>(All Capacities<br>48VDC Only) | A4Z0001VAA  | 48VDC<br>Controller 0-<br>5VDC Control  |    |           |   |
| HETX***B<br>(All Capacities<br>48VDC Only) | A4Z0002VAA  | 48VDC<br>Controller 0-<br>12VDC Control |   |           |   |
| HE_X***B<br>(All Capacities<br>48VDC Only) | Y4S0001RAA  | Thermistor                              |    |           |   |
| HEIX018B<br>HEIX025B                       | C3S0001RAA  | Interior<br>And<br>Exterior<br>Fans     |  |           |   |
| HETX018B<br>HETX025B                       | C3S0002RAA  |   |   |           |   |
| HE*X018M<br>HE*X025M                       | CSG0001EAA  |   |   |           |   |
| HE*X018N<br>HE*X025N                       | C3H0001EAA  |   |   |           |   |
| HEIX035B<br>HEIX045B                       | C3S0003RAA  |   |   |           |   |
| HETX035B<br>HETX045B                       | C3S0004RAA  |   |   |           |   |
| HE*X035M<br>HE*X045M                       | C3G0002ZAA  |   |   |           |   |
| HE*X035N<br>HE*X045N                       | C3H0002ZAA  |   |   |           |   |
| HETX055B<br>HEIX055B                       | C3S0006RAA  |   |   |           |   |
| HE*X055M                                   | C3G0003ZAA  |   |   |           |   |
| HE*X055N                                   | C3H0003ZAA  |   |   |           |   |
| HE*X035M<br>HE*X045M                       | C4G0002ZAA  |   |   | Capacitor |  |
| HE*X035N<br>HE*X045N                       | C4H0002ZAA  |   |   |           |   |
| HE*X055M                                   | C4G0003ZAA  |   |   |           |   |
| HE*X055N                                   | C4H0003ZAA  |   |   |           |   |

### 13. Warranty

## **VOLTAIRE SYSTEMS THERMAL UNITS LIMITED WARRANTY AND LIMITATIONS OF LIABILITY**

**(Applies to All Heat Exchangers, Pressurization Units,  
Fan Units, and Air Conditioners)**

The VoltAire Systems, LLC ("VoltAire") Non-Transferable Limited Warranty ("Limited Warranty") is applicable for 12 months following the shipment of the product to the original purchaser ("Purchaser") defined as the "Warranty Period". VoltAire warrants to the original purchaser during the Warranty Period that all materials and workmanship are free of defects of quality and operation that would impair the usefulness of the original air conditioner, fan unit, or heat exchanger (collectively herein referred to as "Product") during the Warranty Period. This Limited Warranty is for all components of the Product, except filters, when installed and operated under the following conditions:

- A. In strict accordance with the Product's Installation and Operation Manual, as may be revised from time to time with the latest version available at [www.voltairesys.com](http://www.voltairesys.com).
- B. Maximum voltage variation no greater than plus or minus 10% of nameplate nominal rating.
- C. Maximum frequency variation no greater than plus or minus 3 Hz. of nameplate nominal rating.
- D. Must not exceed minimum and maximum stated temperatures on the nameplate.
- E. Not to exceed (BTU/Hr.) rating, including any heat sink, as indicated on the nameplate.
- F. Installed per all local, State and Federal Codes
- G. The unit must not be restarted for a period of five (5) minutes after intentional or accidental shut-off of a compressor. (This does not apply to heat exchangers or pressurization units.)

The Limited Warranty is void and not applicable if:

- A. The Product is installed improperly
- B. The Product is not maintained properly, including prolonged operation with dirty filters or coils.
- C. The Product is modified, abused and/or tampered
- D. The Product is applied in an incorrect manner, including operation within a corrosive atmosphere (including but not limited to coastal applications)
- E. The Product is used with the incorrect refrigerant (air conditioners only)
- F. The Product is damaged and/or inoperable due to accidents or events beyond the reasonable control of VoltAire and Acts of God
- G. The Product is repaired with parts not provided by VoltAire
- H. The Product is installed and operated outside the United States, Mexico, and/or Canada.

Damage during freight is not included with this Limited Warranty. The Purchaser must insure the Product is installed by a competent, professional, qualified contractor, following all local, state, and national codes and industry standards. The Purchaser must provide adequate maintenance (e.g. filter changes, coil cleanings).

The Limited Warranty covers the Product only during the Warranty period, and the Limited Warranty does not include any labor, freight, and/or consequential damages or loss. Upon Notification by the Purchaser, VoltAire solely reserves the right to either:

- Ship replacement parts to the Purchaser for the Purchaser's infield replacement of the part. Infield replacement will require the Purchaser to provide a purchase order to VoltAire for the standard cost of the part and after infield replacement return the original part to VoltAire with freight cost by Purchaser. Within fourteen (14) days of receipt of the returned part VoltAire will review and analyze the returned part. If the part is found to be defective by VoltAire a credit will be issued to the customer. Parts returned to VoltAire and found not to be defective will result in no credit applied to Purchaser's account and the Purchaser will be required to pay for the replacement part.
- Or request the return of the Product for evaluation. Return of the Product must be preceded by the issuance of a VoltAire Return Merchandise Authorization (RMA). The RMA will require that shipping costs be paid by the Purchaser to return the Product to VoltAire. Within fourteen (14) days of receipt of the returned Product VoltAire will review and analyze the Product. If the Product is determined by VoltAire to be defective, VoltAire may repair or replace the Product, and will ship the Product to the Purchaser for the Purchaser's installation in the field with no labor costs reimbursed by VoltAire. If the Product is determined by VoltAire to NOT be defective, the Purchaser will be notified and a Purchase Order must be issued in the amount required for the Product to be Packaged and returned to the Purchaser.

**DISCLAIMERS AND LIMITATIONS OF LIABILITY:**

THIS LIMITED WARRANTY CONSTITUTES THE ENTIRE WARRANTY FOR THE VOLTAIRE PRODUCT AND IS IN LIEU OF ALL OTHER WARRANTIES, EXPRESS AND IMPLIED, INCLUDING ANY WARRANTY OR MERCHANTABILITY AND WARRANTY OF FITNESS FOR A PARTICULAR PURPOSE.

VOLTAIRE IS NOT RESPONSIBLE FOR INCIDENTAL OR CONSEQUENTIAL DAMAGES OF ANY NATURE WHATSOEVER, INCLUDING, BUT NOT LIMITED TO, LOST PROFITS, ATTORNEYS FEES, AND LOSS OF USE DAMAGES.

VOLTAIRE EXCLUDES ALL LIABILITY FOR OR ARISING FROM ANY NEGLIGENCE ON ITS PART OR ON THE PART OF ANY OF ITS EMPLOYEES, AGENTS, OR REPRESENTATIVES IN RESPECT TO THE MANUFACTURE OR SUPPLY OF GOODS, INCLUDING THE PRODUCT, OR THE PROVISION OF SERVICES RELATING TO THE GOODS, INCLUDING THE PRODUCT.

This Limited Warranty, Disclaimer, and Limitation of Liability shall supersede any Terms of Purchase provided by the Purchaser at the time of the Purchase, and the Limitation of Liability shall survive from the date of the Purchase to the date of discontinued use. Some states do not allow the exclusion or limitation of incidental or consequential damages, so the above limitation of consequential damages may not apply.